

## Vertical Rack Mount Evaporator Units

### 2,572 to 6,629 BTU/H Capacity

LRC's Vertical Rack Mount (VRM) Low Noise Evaporators are designed for installation in a corner of a wine room to unobtrusively provide quiet cooling. VRM Evaporators quietly supplies refrigerated and humidity controlled air to medium and high temperature spaces, making them an ideal choice for small to medium size wine rooms.

VRM Evaporator units are available in capacities from 2,572 to 6,629 BTU's per hour and can be used with R-22, R134a or R404a refrigerants. Chilled water models are available by special order.

VRM units have multiple access doors that can be removed as needed for air intake and exhaust depending on how the unit is installed. The VRM's Motor Speed Control (standard) allows for the adjustment of overall airflow through the unit while allowing the room humidity to be maintained within an acceptable range.

Contact LRC's Application Engineers for more information.

- Low noise design for minimum acoustical impact
- Compact design allows unit to be inconspicuously integrated into a wine room decor
- Maintains maximum room humidity to prevent degradation of wine bottle labels or other sensitive items
- High performance staggered coils are baked with AerisGuard™ protective epoxy

- coating for maximum system life. Copper tubing is mechanically expanded into aluminum fins
- Insulated rust-proof aluminum housing
- Coil and primary drain pan is epoxy coated for long life
- Secondary drain pan standard
- Thermally protected motors
- Each coil pressure tested to over 380 psig for maximum system integrity
- Factory wired for easy field installation
- Expansion and liquid line solenoid valve pre-installed

#### Options Available— Call for details

- Copper coils and stainless steel cabinets available for harsh environments
- Humidity controls available
- Pre-charged, custom or OEM units can be made to your order

Our Application Engineers can help you design the system you need. Call us today, 562-944-1969, and we'll help you get the right LRC product for your project.

#### OUR UNCONDITIONAL GUARANTEE

We're proud of the workmanship that goes into every LRC product. Because of our exacting design and manufacturing standards, and our thorough testing prior to shipping, we unconditionally guarantee our products to be free from manufacturing defects for one year. You can count on LRC Coil for quality heat transfer products.

At LRC, we are continuously working to improve our products, therefore, we reserve the right to make changes without notice.



Visit [www.lrccoil.com](http://www.lrccoil.com) for installation and maintenance data, and wiring diagrams.

All measurements are in inches.

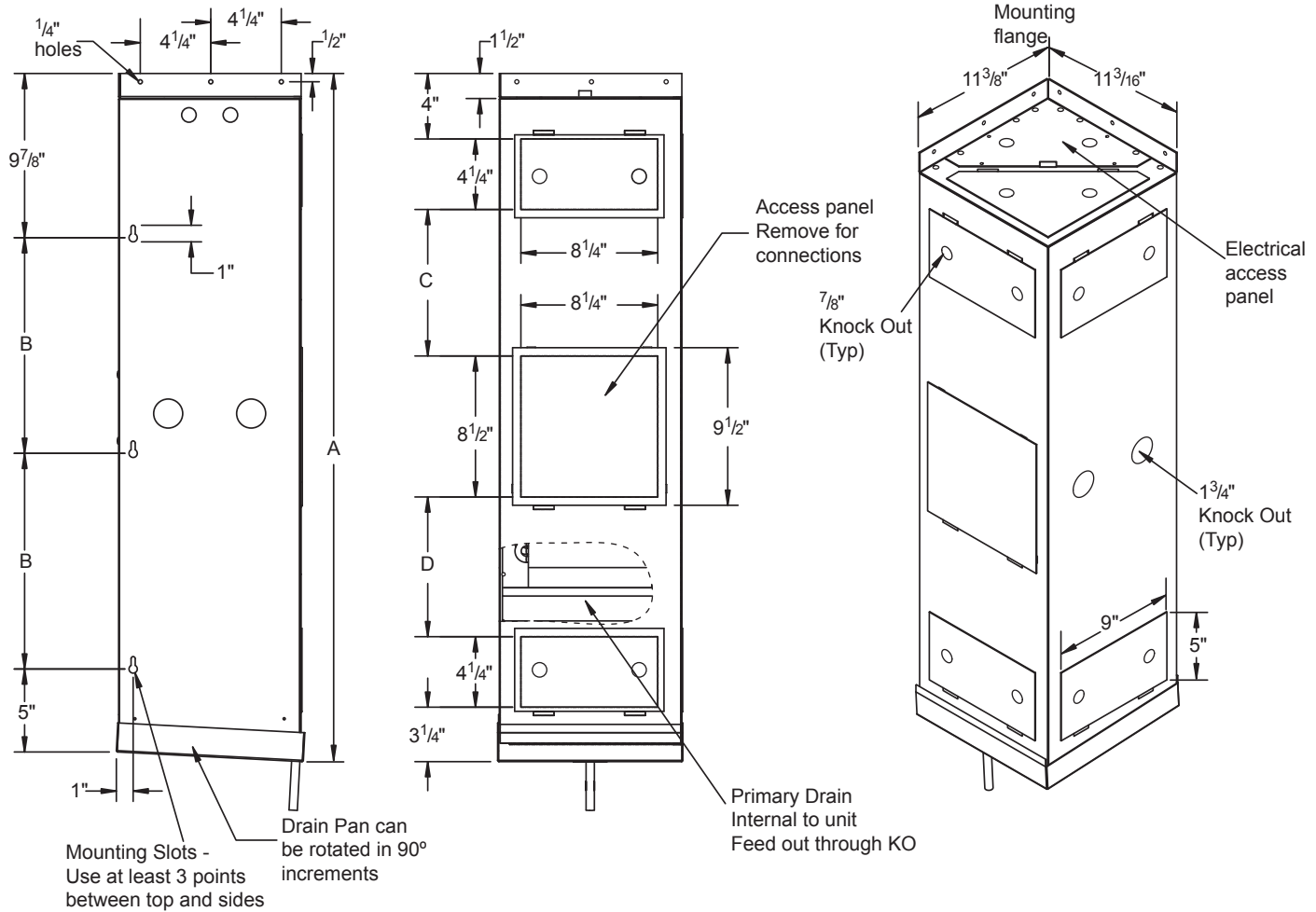

### Vertical Rack Mount (VRM) Specifications

Model No.	115V Amps	CFM	BTUH's	
			R22 - 38° ST @ 55° Room Temp.	R134A - 38° ST @ 55° Room Temp.
VRM-25	0.77	220	2,654	2,572
VRM-35	0.77	260	3,543	3,228
VRM-50	0.77	335	4,996	4,550
VRM-65	1.85	420	6,629	6,500

### Vertical Rack Mount (VRM) Physical Data

Model No.	Dimensions				Connections		Unit Wt.
	A	B	C	D	Liq.	Suct.	
VRM-25	41 1/2	13	8 13/16	8 7/16	3/8	3/8	48
VRM-35	45 1/2	15	9 5/16	11 15/16	3/8	3/8	50
VRM-50	47 1/2	16	9 5/16	13 15/16	3/8	1/2	59
VRM-65	51 1/2	18	NA	NA	3/8	1/2	63

Expansion valve and liquid line solenoid valve standard  
 For air flow into and out of the unit, at least one access door  
 must be removed from each end.  
 Custom configurations available; call factory for details.

Please note:

- LRC cooling units are designed to minimize noise and vibration. To reduce/eliminate amplification of existing noise or vibration, extreme care must be taken during installation. Please refer to supplied installation instructions and use proper installation materials to minimize acoustic impact.
- The use of oversized condensing units can lead to poor wine room evaporator performance and possible system failure. When installing a LRC wine room evaporator, it is recommended that condensing units be sized LESS than or equal to the evaporator capacity. Contact LRC Coil's Application Engineers at 562-944-1969 for assistance.
- LRC recommends evaporator maintenance access is designed into every wine room installation.

Our Application Engineers can help you design the system you need. Call us today, 562-944-1969, and we'll help you get the right LRC product for your project.